

EE 2009

Q. 1 - 20 carry one mark each

- Q.1 The pressure coil of a dynamometer type wattmeter is  
 (A) Highly inductive (B) Highly resistive (C) Purely resistive (D) Purely inductive

Q.2 The measurement system shown in figure uses three sub-systems in cascade whose gains are specified as

$G_1, G_2$  and  $\frac{1}{G_3}$ . The relative small errors associated with each respective subsystem

$G_1, G_2$  and  $G_3$  are  $\epsilon_1, \epsilon_2$  and  $\epsilon_3$ . The error associated with the output is :

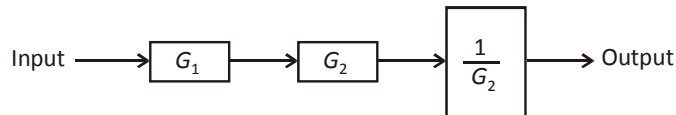

- (A)  $\epsilon_1 + \epsilon_2 + \frac{1}{\epsilon_3}$  (B)  $\frac{\epsilon_1 \cdot \epsilon_2}{\epsilon_3}$  (C)  $\epsilon_1 + \epsilon_2 - \epsilon_3$  (D)  $\epsilon_1 + \epsilon_2 + \epsilon_3$

Q.3 The following circuit has a source voltage  $V_s$  as shown in the graph. The current through the circuit is also shown

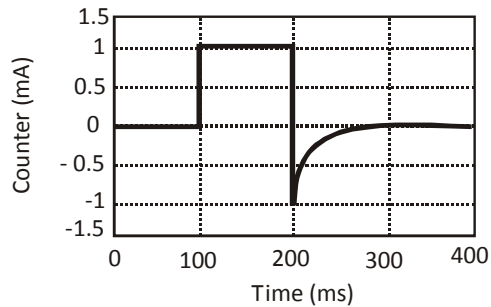
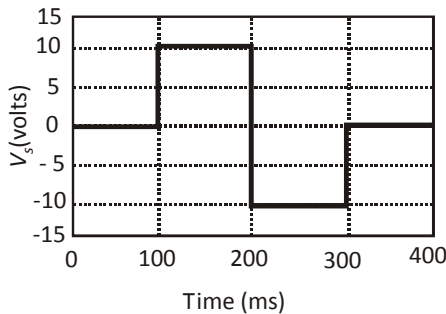
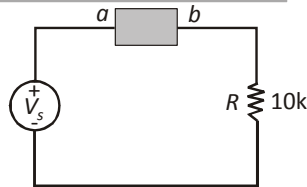

The element connected between a and b could be

- (A) a —|>— b (B) a —|<— b (C) a —||— b (D) a —|<— b

- Q.4 The two inputs of a CRO are fed with two stationary periodic signals. In the X-Y mode, the scree shows a figure which changes from ellipse to circle and back to ellipse with its major axis changing orientation slowly and repeatedly. The following inference can be made from this
- (A) The signals are not sinusoidal  
 (B) The amplitudes of the signal are very close but not equal  
 (C) The signals are sinusoidal with their frequencies very close but not equal  
 (D) There is a constant but small phase difference between the signals
- Q.5 The increasing order of speed of data access for the following devices is
- (i) Cache Memory           (ii) CDROM  
 (iii) Dynamic RAM       (iv) Processor Registers   (v) Magnetic Tape
- (A) (ii), (i), (iii), (iv), (i)   (B) (v), (ii), (iii), (i), (iv)   (C) (ii), (i), (iii), (iv), (v)   (D) (v), (ii), (i), (iii), (iv)
- Q.6 A field excitation of 20 A in a certain alternator results in an armature current of 400 A in short circuit and a terminal voltage of 2000 V on open circuit. The magnitude of the internal voltage drop within the machine at a load current of 200 A is
- (A) 1 V                           (B) 10 V                           (C) 100 V                           (D) 1000 V
- Q.7 The current through the 2kΩ resistance in the circuit shown is

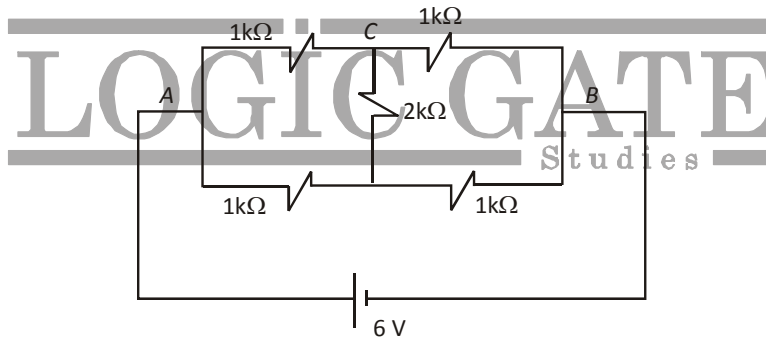

- (A) 0 mA                           (B) 1 mA                           (C) 2 mA                           (D) 6 mA
- Q.8 Out of the following plant categories
- (i) Nuclear                           (ii) Run-of-river                           (iii) Pump Storage                           (iv) Diesel
- the base load power plants are
- (A) (i) and (ii)                           (B) (ii) and (iii)                           (C) (i), (ii) and (iv)                           (D) (i), (ii) and (iv)
- Q.9 For a fixed value of complex power flow in a transmission line having a sending end voltage V, the real power loss will be proportional to
- (A) V                           (B) V<sup>2</sup>                           (C) 1/V<sup>2</sup>                           (D) 1/V
- Q.10 How many 200W/220V incandescent lamps connected in series would consume the same total power as a single 100W/220V incandescent lamp ?
- (A) Not possible                           (B) 4                           (C) 3                           (D) 2

Q.11 A Linear Time Invariant system with an impulse response  $h(t)$  produces output  $y(t)$  when input  $x(t)$  is applied.

When the input  $x(t - \tau)$  is applied to a system with impulse response  $h(t - \tau)$ , the output will be

- (A)  $y(t)$                       (B)  $y(2(t - \tau))$                       (C)  $y(t - \tau)$                       (D)  $y(t - 2\tau)$

Q.12 The nature of feedback in the opamp circuit shown is

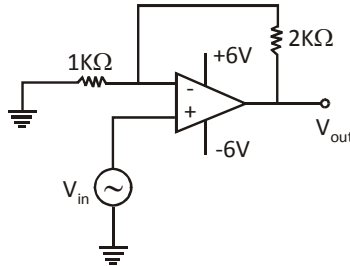

- (A) Current - Current feedback                      (B) Voltage - Voltage feedback  
(C) Current - Voltage feedback                      (D) Voltage - Current feedback

Q.13 The complete set of only those Logic Gate designated as Universal Gates is

- (A) NOT, OR and AND Gates                      (B) XNOR, NOR and NAND Gates  
(C) NOR and NAND Gates                      (D) XOR, NOR and NAND Gates

Q.14 The single phase, 50Hz, iron core transformer in the circuit has both the vertical arms of cross sectional area  $20 \text{ cm}^2$  and both the horizontal arms of cross sectional area  $10 \text{ cm}^2$ . If the two windings shown were wound instead on opposite horizontal arms, the mutual inductance will

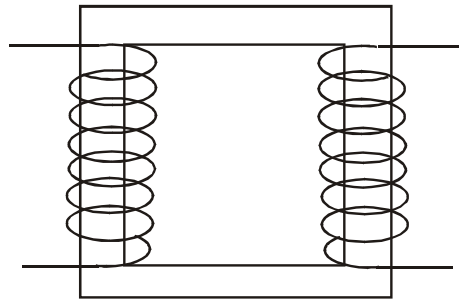

- (A) Double                      (B) Remain Same                      (C) Be halved                      (D) Become one quarter

- Q.15 A 3-phase squirrel cage induction motor supplied from a balanced 3-phase source drives a mechanical load. The torque-speed characteristics of the motor (solid curve) and of the load (dotted curve) are shown. Of the two equilibrium points A and B, which of the following options correctly describes the stability of A and B ?

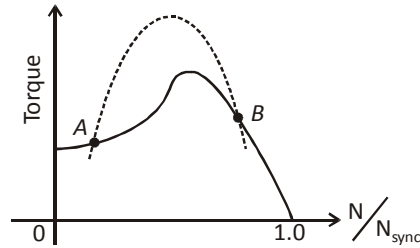

- (A) A is stable B is unstable  
 (B) A is unstable B is stable  
 (C) Both are stable  
 (D) both are unstable

- Q.16 An SCR is considered to be semi-controlled device because

- (A) It can be turned OFF but not ON with a gate pulse  
 (B) It conducts only during one half-cycle of an alternating current wave  
 (C) It can be turned ON but not OFF with a gate pulse  
 (D) It can be turned ON only during one half-cycle of an alternating voltage wave

- Q.17 The polar plot of an open loop stable system is shown below. The closed loop system is

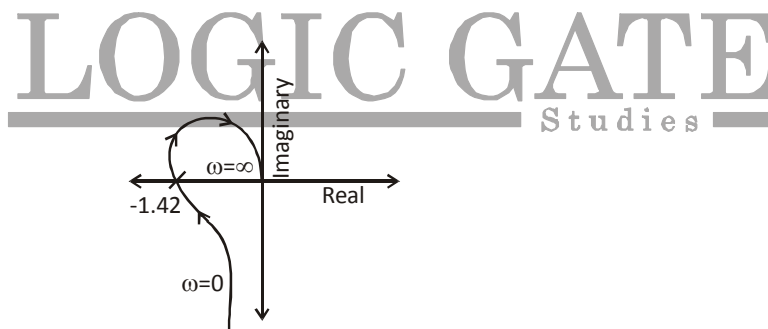

- (A) Always stable  
 (B) Marginally stable  
 (C) Unstable with one pole on the RH s-plane  
 (D) Unstable with two poles on the RH s-plane

- Q.18 The first two rows of Routh's tabulation of a third order equation are as follows.

$$\begin{matrix} s^3 & 2 & 2 \\ s^2 & 4 & 4 \end{matrix}$$

This means there are

- (A) Two roots at  $s = \pm j$  and one root in right half s-plane  
 (B) Two roots at  $s = \pm j 2$  and one root in left half s-plane  
 (C) Two roots at  $s = \pm j 2$  and one root in right half s-plane  
 (D) Two roots at  $s = \pm j$  and one root in left half s-plane

Q.19 The asymptotic approximation of the log-magnitude vs frequency plot of a system containing only real poles and zeros is shown. Its transfer function is

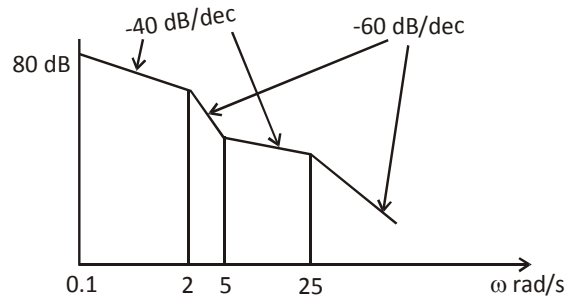

- (A)  $\frac{10(s+5)}{s(s+2)(s+25)}$       (B)  $\frac{1000(s+5)}{s^2(s+2)(s+25)}$       (C)  $\frac{100(s+5)}{s^2(s+2)(s+25)}$       (D)  $\frac{80(s+5)}{s^2(s+2)(s+25)}$

Q.20 The trace and determinant of a  $2 \times 2$  matrix are known to be -2 and -35 respectively. Its eigenvalues are  
 (A) -30 and -5      (B) -37 and -1      (C) -7 and 5      (D) 17.5 and -2

**Q.21 to Q.60 carry two marks each**

Q.21 The following circuit has  $R = 10 \text{ k}\Omega$ ,  $C = 10 \text{ }\mu\text{F}$ . The input voltage is a sinusoid at 50 Hz with an rms value of 10V. Under ideal conditions, the current  $i_s$  from the source is

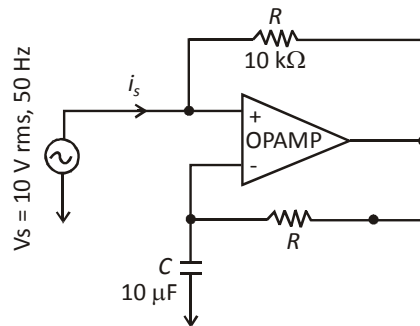

- (A)  $10\pi \text{ mA}$  leading by  $90^\circ$     (B)  $20\pi \text{ mA}$  leading by  $90^\circ$     (C)  $10 \text{ mA}$  leading by  $90^\circ$     (D)  $10\pi \text{ mA}$  leading by  $90^\circ$

- Q.22 In the figure shown, all elements used are ideal. For time  $t < 0$ ,  $S_1$  remained closed and  $S_2$  open. At  $t = 0$ ,  $S_1$  is opened and  $S_2$  is closed. If the voltage  $V_{C_2}$  across the capacitor combination at  $t = 0^+$  will be

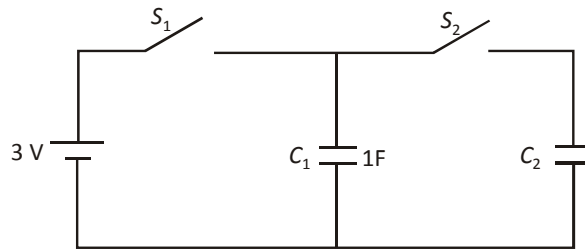

- (A) 1 V                      (B) 2 V                      (C) 1.5 V                      (D) 3 V
- Q.23 Transformer and emitter follower can both be used for impedance matching at the output of a audio amplifier. The basic relationship between the input power  $P_{in}$  and output power  $P_{out}$  in both the cases is
- (A)  $P_{in} = P_{out}$  for both transformer and emitter follower  
 (B)  $P_{in} > P_{out}$  for both transformer and emitter follower  
 (C)  $P_{in} < P_{out}$  for transformer and  $P_{in} = P_{out}$  for emitter follower  
 (D)  $P_{in} = P_{out}$  for transformer and  $P_{in} < P_{out}$  for emitter follower

- Q.24 The equivalent capacitance of the input loop of the circuit shown is

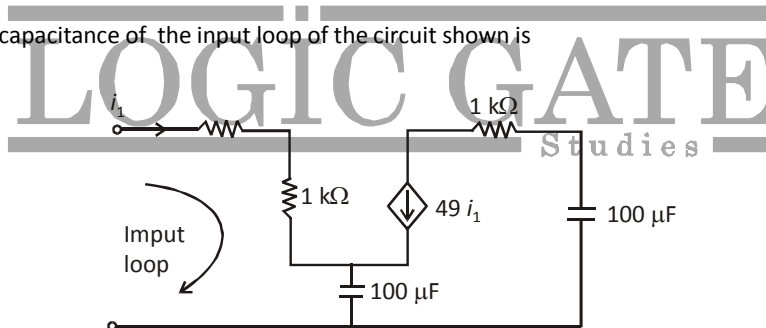

- (A)  $2\mu\text{F}$                       (B)  $100\mu\text{F}$                       (C)  $200\mu\text{F}$                       (D)  $4\mu\text{F}$
- Q.25 In an 8085 microprocessor, the contents of the Accumulator, after the following instructions are executed will become
- XRA A**  
**MVIB FOH**  
**SUB B**
- (A) 01 H                      (B) 0 FH                      (C) F 0 H                      (D) 10 H

Q.26 For the Y-bus matrix of a 4-bus system given in per unit, the buses having shunt elements are

$$Y_{BUS} = \begin{bmatrix} -5 & 2 & 2.5 & 0 \\ 2 & -10 & 2.5 & 4 \\ 2.5 & 2.5 & -9 & 4 \\ 0 & 4 & 4 & -8 \end{bmatrix}$$

- (A) 3 and 4                      (B) 2 and 3                      (C) 1 and 2                      (D) 1, 2 and 4

Q.27 The unit-step response of a unity feedback system with open loop transfer function  $G(s) = K / ((s+1)(s+2))$  is shown in the figure. The value of K is

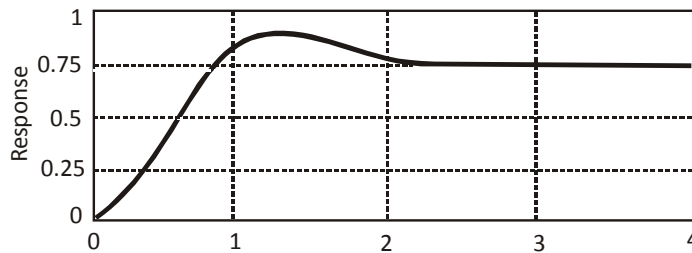

- (A) 0.5                      (B) 2                      (C) 4                      (D) 6

Q.28 The open loop transfer function of a unity feedback system is given by  $G(s) = (e^{-0.1s})/s$ . The gain margin of this system is

- (A) 11.95 dB                      (B) 17.67 dB                      (C) 21.33 dB                      (D) 23.9 dB

Q.29 Match the items in List-I with the items in List-II and select the correct answer using the codes given below the lists

List - I

List - II

To

Use

- a. Improve power factor
- b. Reduce the current ripples
- c. Increase the power flow in line
- d. Reduce the Ferranti effect

- 1. Shunt reactor
- 2. Shunt capacitor
- 3. Series capacitor
- 4. Series reactor

(A)  $a \rightarrow 2, b \rightarrow 3, c \rightarrow 4, d \rightarrow 1$

(B)  $a \rightarrow 3, b \rightarrow 2, c \rightarrow 3, d \rightarrow 1$

(C)  $a \rightarrow 4, b \rightarrow 3, c \rightarrow 1, d \rightarrow 2$

(D)  $a \rightarrow 4, b \rightarrow 1, c \rightarrow 3, d \rightarrow 2$

Q.30 Match the items in List-I with the items in List-II and select the correct answer using the codes given below the lists

List - I

List - II

Type of transmission line

Type of distance relay preferred

- a. Short Line
- b. Medium Line
- c. Long Line

- 1. Ohm Relay
- 2. Reactance Relay
- 3. Mho Relay

(A)  $a \rightarrow 2, b \rightarrow 1, c \rightarrow 3$

(B)  $a \rightarrow 3, b \rightarrow 2, c \rightarrow 3$

(C)  $a \rightarrow 1, b \rightarrow 2, c \rightarrow 3$

(D)  $a \rightarrow 1, b \rightarrow 3, c \rightarrow 2$

Q.31 Three generators are feeding a load of 100 MW. The details of the generators are

Rating (MW) Efficiency (%) Regulation (p.u.) on 100 MVA base

Generator-1	100	20	0.02
Generator-2	100	30	0.04
Generator-3	100	40	0.03

All the generators will share equal power

- (B) Generator - 3 will share more power compared to Generator - 1
- (C) Generator - 1 will share more power compared to Generator - 2
- (D) Generator - 2 will share more power compared to Generator - 3

Q.32 A 500 MW, 21 kV, 50 Hz, 3 - phase, 2-pole synchronous generator having a rated p.f. = 9.9, has a moment of inertia of  $27 \cdot 5 \times 10^3 \text{ kg-m}^2$ . The inertia constant (H) will be

- (A) 2.44 s
- (B) 2.71 s
- (C) 4.88 s
- (D) 5.42 s

Q.33  $f(x,y)$  is a continuous function defined over  $(x,y) \in [0,1] \times [0,1]$ . Given the two constraints,  $x > y^2$  and  $y > x^2$ , the volume under  $f(x,y)$  is

(A)  $\int_{y=0}^{y=1} \int_{x=y^2}^{x=\sqrt{y}} f(x,y) dx dy$       (B)  $\int_{y=x^2}^{y=1} \int_{x=y^2}^{x=1} f(x,y) dx dy$       (C)  $\int_{y=0}^{y=1} \int_{x=0}^{x=1} f(x,y) dx dy$       (D)  $\int_{y=0}^{y=\sqrt{x}} \int_{x=0}^{x=\sqrt{y}} f(x,y) dx dy$

Q.34 Assume for simplicity that N People, All born in Aripil (a month of 30 days), are collected in a room. Consider the event of at least two people in the room being born on the same date of the month, even if in different years, e.g. 1998 and 1995. What is the smallest N so that the probability of this event exceeds 0.5?

- (A) 20
- (B) 7
- (C) 15
- (D) 16

Q.35 A cascade of 3 Linear Time Invariant systems is causal and unstable. Form this, we conclude that

- (A) Each system in the cascade is individually causal and unstable
- (B) At least one system is unstable and at least one system is causal
- (C) At least one system is causal and all systems are unstable
- (D) The majority are unstable and the majority are causal

Q.36 The Fourier Series coefficients, of a periodic signal  $x(t)$ , expressed as  $x(t) = \sum_{k=-\infty}^{\infty} a_k e^{j2\pi kt/T}$  are given by

$a_{-2} = 2 - j1; a_{-1} = 0 \cdot 5 + j0 \cdot 2; a_0 = j2; a_1 = 0 \cdot 5 - j0 \cdot 2; a_2 = 2 + j1$ ; and  $a_k = 0$ ; for  $|k| > 2$ . Which of the following is true ?

- (A)  $x(t)$  has finite energy because only finitely many coefficients are non-zero
- (B)  $x(t)$  has zero average value because it is periodic
- (C) The imaginary part of  $x(t)$  is constant
- (D) The real part of  $x(t)$  is even

Q.37 The z-transform of a signal  $x[n]$  is given by  $4z^{-3} + 3z^{-1} + 2 - 6z^2$ . It is applied to a system, with a transfer function  $H(z) = 3z^{-1} - 2$ . Let the output be  $y(n)$ . Which of the following is true?

- (A)  $y(n)$  is causal with finite support
- (B)  $y(n)$  is causal with infinite support
- (C)  $y(n) = 0; |n| > 3$
- (D)  $\text{Re}[Y(z)]_{z=e^{j\theta}} = -\text{Re}[Y(z)]_{z=e^{-j\theta}}; \text{Im}[Y(z)]_{z=e^{-j\theta}}; -\pi \leq \theta < \pi$

Q.38 A cubic polynomial with real coefficients

- (A) Can possibly have no extrema and no zero crossings
- (B) May have up to three extrema and upto 2 zero crossings
- (C) Cannot have more than two extrema and more than three zero crossings
- (D) Will always have an equal number of extrema and zero crossings

Q.39 Let  $x^2 - 117 = 0$ . The iterative steps for the solution using Newton-Raphson's method is given by

- (A)  $x_{k+1} = \frac{1}{2} \left( x_k + \frac{117}{x_k} \right)$
- (B)  $x_{k+1} = x_k - \frac{117}{x_k}$
- (C)  $x_{k+1} = x_k - \frac{x_k}{117}$
- (D)  $x_{k+1} = x_k - \frac{1}{2} \left( x_k + \frac{117}{x_k} \right)$

Q.40  $F(x, y) = (x^2 + xy)\hat{a}_x + (y^2 + xy)\hat{a}_y$ . It's line integral over the straight line from  $(x, y) = (0, 2)$  to  $(x, y) = (2, 0)$  evaluates to

- (A) -8
- (B) 4
- (C) 8
- (D) 0

Q.41 An ideal opamp circuit and its input waveform are shown in the figures. The output waveform of this

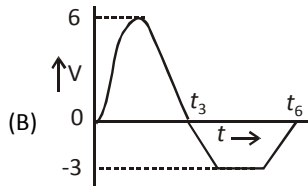
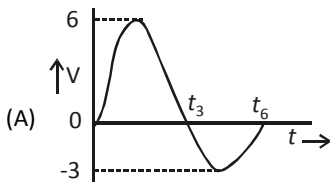
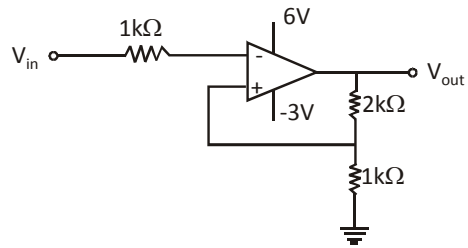
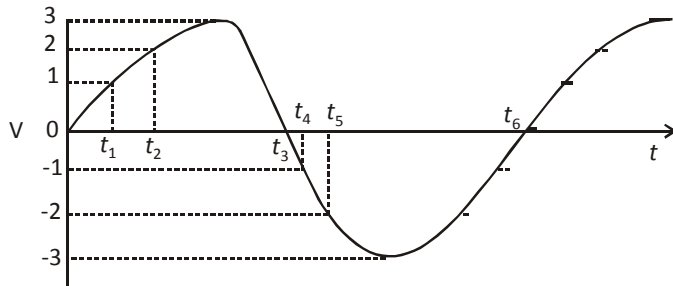

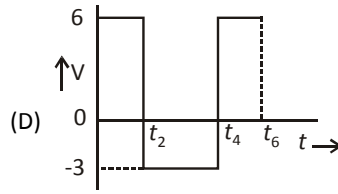
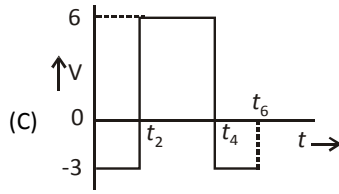

Q.42 A 220 V, 50 Hz, single-phase induction motor has the following connection diagram and winding orientations shown. MM' is the axis of the main stator winding ( $M_1 M_2$ ) and AA' is that of the auxiliary winding ( $A_1 A_2$ ). Directions of the winding axes indicate direction of flux when currents in the windings are in the directions shown. Parameters of each winding are indicated. When switch S is closed, the motor

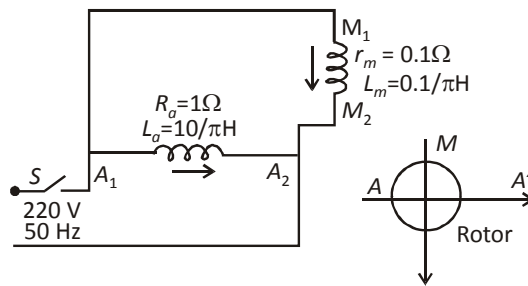

- (A) Rotates clockwise
- (B) Rotates anticlockwise
- (C) Does not rotate
- (D) Rotates momentarily and comes to a halt

Q.43 The circuit shows an ideal diode connected to a pure inductor and is connected to a purely sinusoidal 50 Hz voltage source. Under ideal conditions the current waveform through the inductor will look like

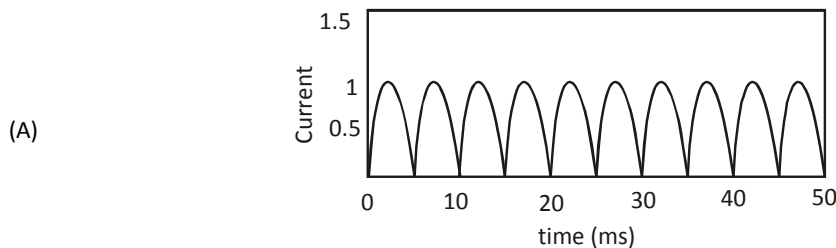
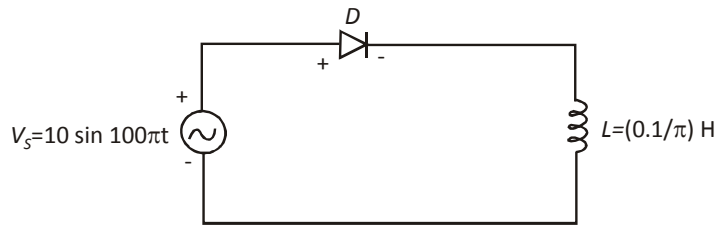

(B)

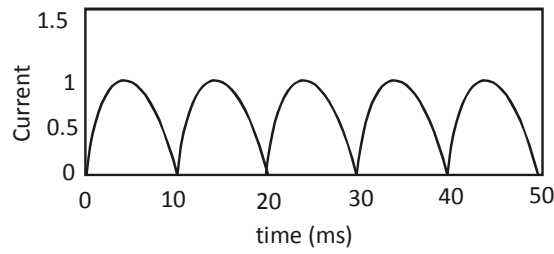

(C)

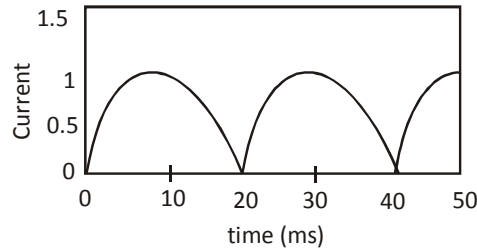

(D)

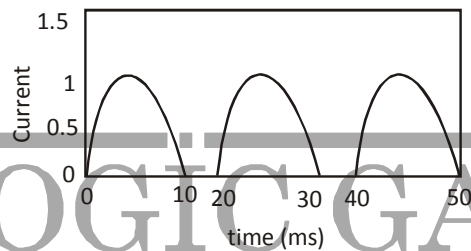

Q.44 The Current Source Inverter shown in figure is operated by alternately turning on thyristor pairs  $(T_1, T_2)$  and  $(T_3, T_4)$ .  
If the load is purely resistive, the theoretical maximum output frequency obtainable will be

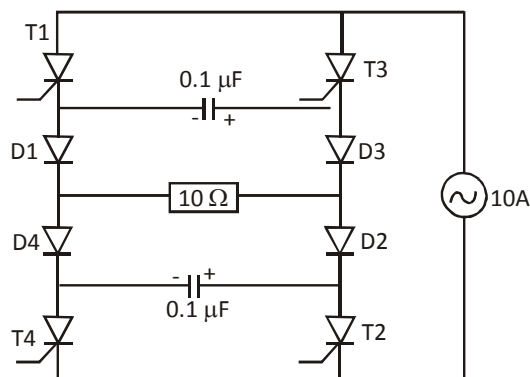

(A) 125 kHz

(B) 250 kHz

(C) 500 kHz

(D) 50 kHz

Q.45 In the chopper circuit shown, the main thyristor ( $T_m$ ) is operated at a duty ratio of 0.8 which is much larger the commutation interval. If the maximum allowable reapplied  $dv/dt$  on TM is  $50 \text{ V}/\mu\text{s}$

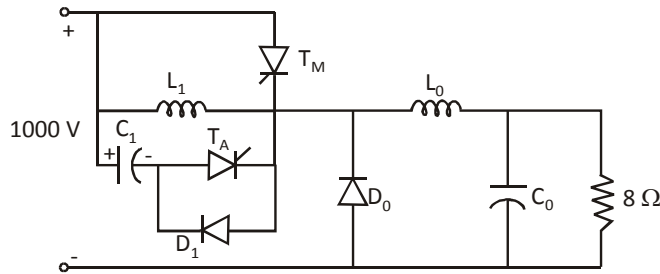

- (A)  $0.2 \mu\text{F}$                       (B)  $0.02 \mu\text{F}$                       (C)  $2 \mu\text{F}$                       (D)  $20 \mu\text{F}$

Q.46 Match the switch arrangements on the top row to the steady-state V-I characteristics on the lower row. The steady state operating points are shown by large black dots

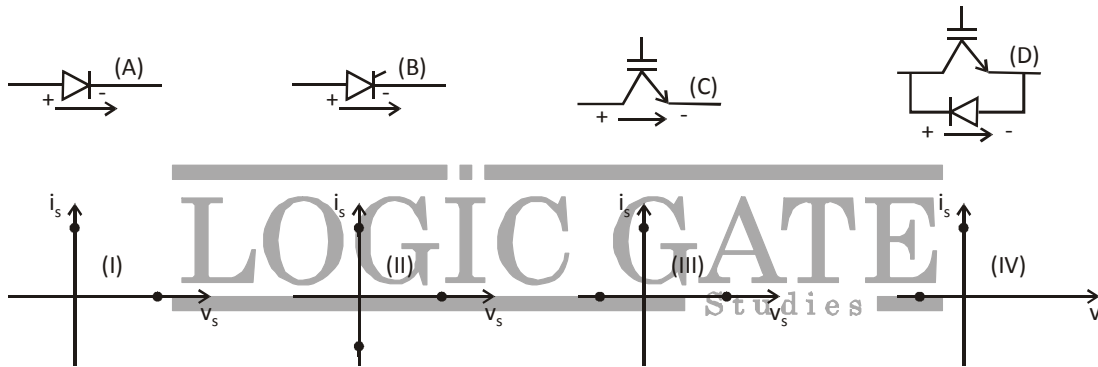

- (A) A-I, B-II, C-III, D-IV    (B) A-II, B-IV, C-I, D-III    (C) A-IV, B-III, C-I, D-II    (D) A-IV, B-III, C-II, D-I

Q.47 For the circuit shown, find out the current flowing through the  $2\Omega$  resistance. Also identify the changes to be made to double the current through the  $2\Omega$  resistance

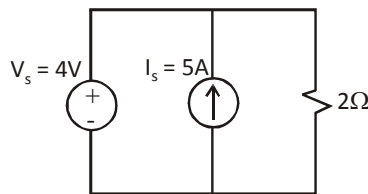

- (A) (5A; Put  $V_s = 20\text{V}$ )    (B) (2A; Put  $V_s = 8\text{V}$ )    (C) (5A; Put  $V_s = 10\text{A}$ )    (D) (7A; Put  $I_s = 12\text{A}$ )

Q.48 The figure shows a three-phase delta connected load supplied from a 400 V, 50 Hz, 3-phase balanced source. The pressure coil (PC) and current Coil (CC) of a wattmeter are connected to the load as shown, with the coil polarities suitably selected to ensure a positive deflection. The wattmeter reading will be

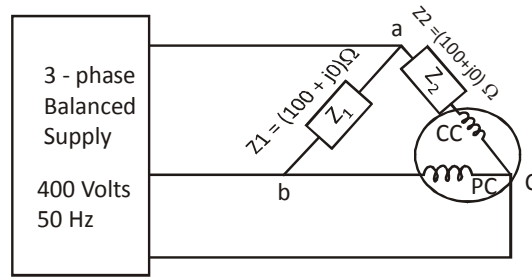

- (A) 0                      (B) 1600 Watt                      (C) 800 Watt                      (D) 400 Watt

Q.49 An average-reading digital multimeter reads 10V when fed with a triangular wave, symmetric about the time-axis. For the same input an rms-reading meter will read

- (A)  $20/\sqrt{3}$                       (B)  $10/\sqrt{3}$                       (C)  $20\sqrt{3}$                       (D)  $10\sqrt{3}$

Q.50 Figure shows the extended view of a 2 pole dc machine with 10 armature conductors. Normal brush positions are shown by A and B, placed at the interpolar axis. If the brushes are now shifted, in the direction of rotation, to A' and B' as shown, the voltage waveform  $V_{A'B'}$  will resemble

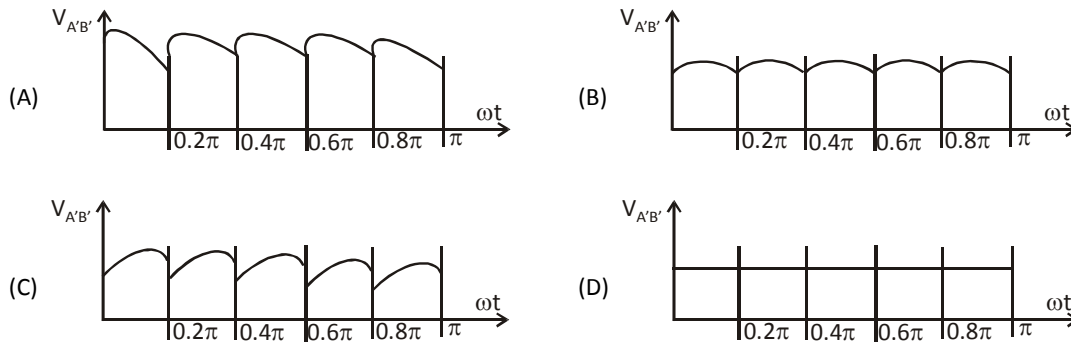
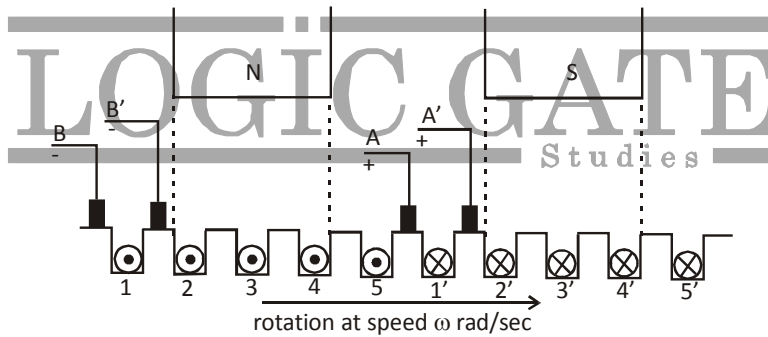

Common Data Questions

Common Data for Questions 51 and 52 :

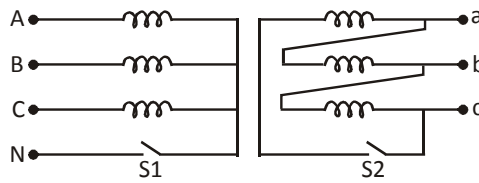

The star-delta transformer shown above is excited on the star side with a balanced, 4-wire, 3-phase, sinusoidal voltage supply of rated magnitude. The transformer is under no load condition.

- Q.51 With both S1 and S2 open, the core flux waveform will be  
 (A) A sinusoid at fundamental frequency (B) Flat-topped with third harmonic  
 (C) Peaky with third-harmonic (D) None of these
- Q.52 With S2 closed and S1 open, the current waveform in the delta winding will be  
 (A) A sinusoid at fundamental frequency (B) Flat-topped with third harmonic  
 (B) Only third-harmonic (D) None of these

Common Data for Questions 53 and 54 :

The circuit diagram shows a two-winding, lossless transformer with no leakage flux, excited from a current source,  $i(t)$ , whose waveform is also shown. The transformer has a magnetizing inductance of  $400/\pi$  mH.

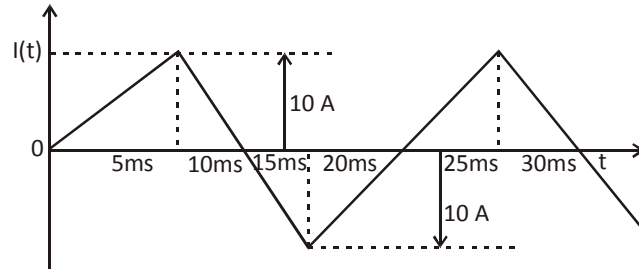
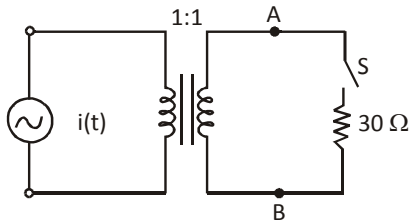

- Q.53 The peak voltage across A and B, with S open is  
 (A)  $400/\pi$  V (B) 800 V (C)  $4000/\pi$  V (D)  $8000/\pi$  V
- Q.54 If the waveform of  $i(t)$  is changed to  $i(t) = 10\sin(100\pi t)$  A, the peak voltage across A and B with S closed is  
 (A) 400 V (B) 240 V (C) 320 V (D) 160 V

**Common Data Questions 55 and 56 :**

A system is described by the following state and output equations

$$\frac{dx_1(t)}{dt} = -3x_1 + x_2(t) + 2u(t)$$

$$\frac{dx_2(t)}{dt} = -2x_2(t) + u(t)$$

$$y(t) = x_1(t)$$

where  $u(t)$  is the input and  $y(t)$  is the output

Q.55 The system transfer function is

- (A)  $\frac{s+2}{s^2+5s-6}$       (B)  $\frac{s+3}{s^2+5s+6}$       (C)  $\frac{2s+5}{s^2+5s+6}$       (D)  $\frac{2s+5}{s^2+5s-6}$

Q.56 The state-transition matrix of the above system is

- (A)  $\begin{bmatrix} e^{-3t} & 0 \\ e^{-2t} + e^{-3t} & e^{-2t} \end{bmatrix}$       (B)  $\begin{bmatrix} e^{-3t} & e^{-2t} - e^{-3t} \\ 0 & e^{-2t} \end{bmatrix}$       (C)  $\begin{bmatrix} e^{-3t} & e^{-2t} + e^{-3t} \\ 0 & e^{-2t} \end{bmatrix}$       (D)  $\begin{bmatrix} e^{3t} & e^{-2t} - e^{-3} \\ 0 & e^{-2t} \end{bmatrix}$

**Linked Answer Questions**

**Statement for Linked Answer Questions 57 and 58 :**

The Figure above shows coils 1 and 2, with dot markings as shown, having 4000 and 6000 turns respectively. Both the coils have a rated current of 25 A. Coil 1 is excited with single phase, 400 V, 50 Hz supply

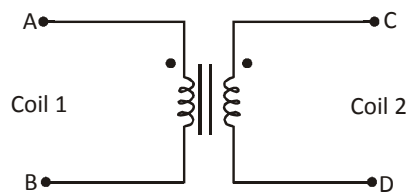

Q.57 The coils are to be connected to obtain a single phase, 400/1000 V, auto-transformer to drive a load of 10 kVA. Which of the options given should be exercised to realize the required auto-transformer ?

- (A) Connect A and D; Common B      (B) Connect B and D; Common C  
(C) Connect A and C; Common B      (D) Connect A and C; Common D

Q.58 In the autotransformer obtained in Question 57, the current in each coil is

- (A) Coil-1 is 25 A and Coil-2 is 10 A      (B) Coil-1 is 10 A and Coil-2 is 25 A  
(C) Coil-1 is 10 A and Coil-2 is 15 A      (D) Coil-1 is 15 A and Coil-2 is 10 A

Statement for Linked Answer Questions 59 and 60 :

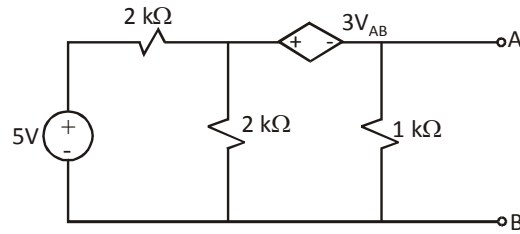

- Q.59 For the circuit given above, the Thevenin's resistance across the terminals A and B is  
 (A) 0.5 kΩ                      (B) 0.2 kΩ                      (C) 1 kΩ                      (D) 0.11 kΩ
- Q.60 For the circuit given above, the Thevenin's voltage across the terminals A and B is  
 (A) 1.25 V                      (B) 0.25 V                      (C) 1 V                      (D) 0.5 V

**END OF THE QUESTION PAPER**