

Electrical 2010

Q.1 to Q.25 Carry one mark each

- Q.1 The value of the quantity  $P$ , where  $P = \int_0^1 x e^x dx$ , is equal to  
 (A) 0 (B) 1 (C)  $e$  (D)  $1/e$
- Q.2 Divergence of the three-dimensional radial vector field  $\frac{1}{r}$  is  
 (A) 3 (B)  $1/r$  (C)  $\hat{i} + \hat{j} + \hat{k}$  (D)  $3(\hat{i} + \hat{j} + \hat{k})$
- Q.3 The period of the signal  $x(t) = 8 \sin\left(0.8\pi t + \frac{\pi}{4}\right)$  is  
 (A)  $0.4\pi$  s (B)  $0.8\pi$  s (C) 1.25 s (D) 2.5 s
- Q.4 The system represented by the input-output relationship  $y(t) = \int_{-\infty}^{5t} x(\tau) d\tau, t > 0$  is  
 (A) Linear and causal (B) Linear but not causal  
 (C) Causal but not linear (D) Neither linear nor causal
- Q.5 The switch in the circuit has been closed for a long time. It is opened at  $t = 0$ . At  $t = 0^+$ , the current through the  $1\mu\text{F}$  capacitor is

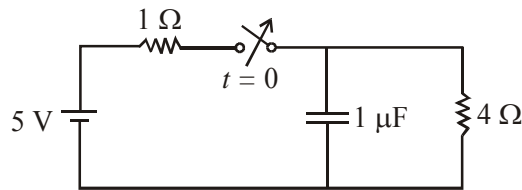

- (A) 0 A (B) 1 A (C) 1.25 A (D) 5 A
- Q.6 The second harmonic component of the periodic waveform given in the figure has an amplitude of

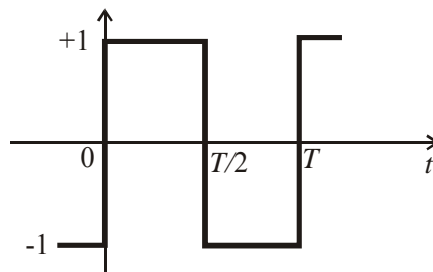

- (A) 0 (B) 1 (C)  $2/\pi$  (D)  $\sqrt{5}$

Q.7 As shown in the figure, a  $1\Omega$  resistance is connected across a source that has a load line  $v + i = 100$ . The current through the resistance is

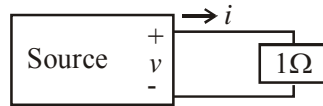

- (A) 25 A                      (B) 50 A                      (C) 100 A                      (D) 200 A

Q.8 A wattmeter is connected as shown in the figure. The wattmeter reads

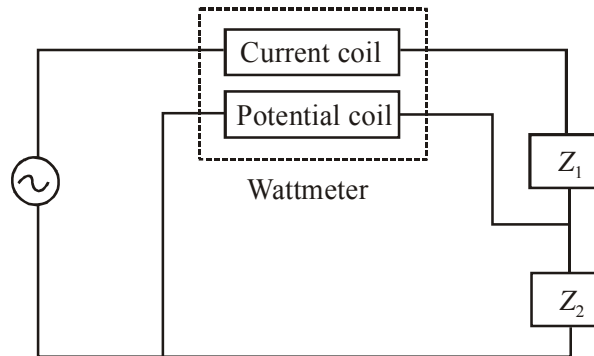

- (A) Zero always                      (B) Total power consumed by  $Z_1$  and  $Z_2$   
 (C) Power consumed by  $Z_1$                       (D) Power consumed by  $Z_2$

Q.9 An ammeter has a current range of 0-5 A, and its internal resistance is  $0.2\Omega$ . In order to change the range to 0-25 A, we need to add a resistance of

- (A)  $0.8\Omega$  in series with the meter                      (B)  $1.0\Omega$  in series with the meter  
 (C)  $1.04\Omega$  in parallel with the meter                      (D)  $1.05\Omega$  in parallel with the meter

Q.10 As shown in the figure, a negative feedback system has an amplifier of gain 100 with  $\pm 10\%$  tolerance in the forward path, and an attenuator of value  $9/100$  in the feedback path. the overall system gain is approximately:

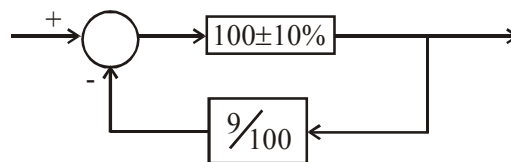

- (A)  $10 \pm 1\%$                       (B)  $10 \pm 2\%$                       (C)  $10 \pm 5\%$                       (D)  $10 \pm 10\%$

Q.11 For the system  $\frac{2}{(s+1)}$ , the approximate time taken for a step response to reach 98% of its final

- (A) 1 s                      (B) 2 s                      (C) 4 s                      (D) 8 s

Q.12 If the electrical circuit of figure (b) is an equivalent of the coupled tank system of figure (a), then

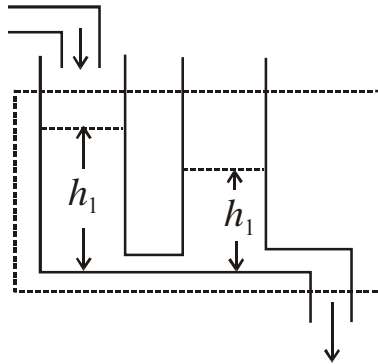

(A) Coupled tank

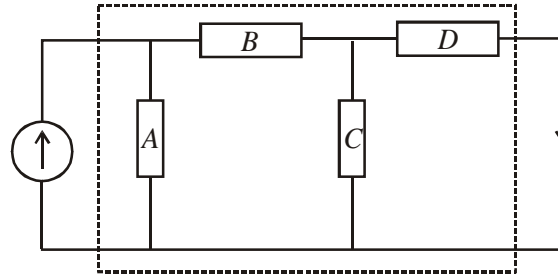

(B) Electrical equivalent

- (A) A, B are resistances and C, D capacitances    (B) A, C are resistances and B, D capacitances  
 (C) A, B are capacitances and C, D resistances    (D) A, C are capacitances and B, D resistances

Q.13 A single-phase transformer has a turns ratio of 1:2, and is connected to a purely resistive load as shown in the figure. The magnetizing current drawn is 1 A, and the secondary current is 1A. If core losses and leakage reactances are neglected, the primary currents is

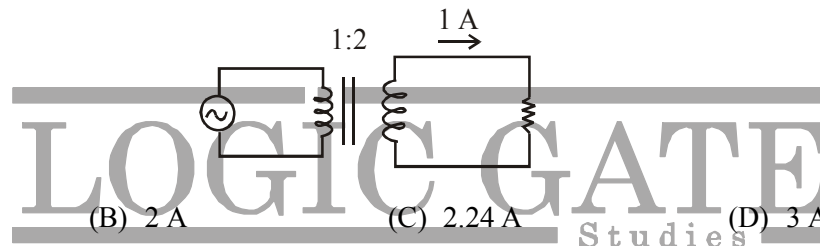

- (A) 1.41 A    (B) 2 A    (C) 2.24 A    (D) 3 A

Q.14 Power is transferred from system A to system B by an HVDC link as shown in the figure. If the voltages  $V_{AB}$  and  $V_{CD}$  are as indicated in the figure, and  $I > 0$ , then

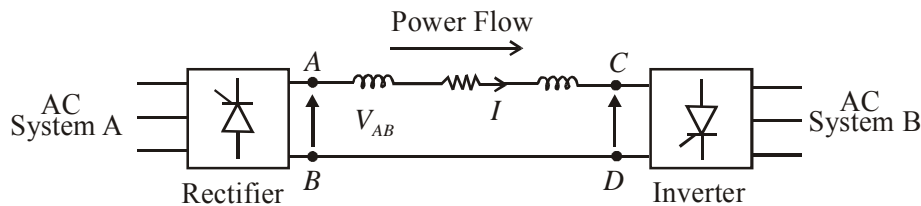

- (A)  $V_{AB} < 0, V_{CD} < 0, V_{AB} > V_{CD}$     (B)  $V_{AB} > 0, V_{CD} > 0, V_{AB} < V_{CD}$   
 (C)  $V_{AB} > 0, V_{CD} > 0, V_{AB} > V_{CD}$     (D)  $V_{AB} > 0, V_{CD} < 0$

Q.15 A balanced three-phase voltage is applied to a star-connected induction motor, the phase to neutral voltage being  $V$ . The stator resistance, rotor resistance referred to the stator, stator leakage reactance, rotor leakage reactance referred to the stator, and the magnetizing reactance are denoted by  $r_s, r_r, x_s, x_r$ , and  $X_m$ , respectively. The magnitude of the starting current of the motor is given by :

(A)  $\frac{V}{\sqrt{(r_s + r_r')^2 + (x_s + x_r')^2}}$

(B)  $\frac{V}{\sqrt{r_s^2 + (x_s + X_m)^2}}$

(C)  $\frac{V}{\sqrt{(r_s + r_r')^2 + (X_m + x_r')^2}}$

(D)  $\frac{V}{\sqrt{r_s^2 + (X_m + x_r')^2}}$

Q.16 Consider a step voltage wave of magnitude 1 pu travelling along a lossless transmission line that terminates in a reactor. The voltage magnitude across the reactor at the instant the travelling wave reaches the reactor is



- (A) -1 pu                      (B) 1 pu                      (C) 2 pu                      (D) 3 pu

Q.17 Consider two buses connected by an impedance of  $(0 + j5)\Omega$ . The bus 1 voltage is  $100\angle 30^\circ\text{V}$ , and bus 2 voltage is  $100\angle 0^\circ\text{V}$ . The real and reactive power supplied by bus 1, respectively, are

- (A) 1000 W, 268 V Ar                      (B) -10000 W, -134 V Ar  
(C) 276.9 W, -56.7 V Ar                      (D) -276.9 W, 56.7 V Ar

Q.18 A three-phase, 33 kV oil circuit breaker is rated 1200 A, 2000 MVA, 3 s. The symmetrical breaking current is

- (A) 1200 A                      (B) 3600 A                      (C) 35 kA                      (D) 104.8 kA

Q.19 Consider a stator winding of an alternator with an internal high-resistance ground fault. The currents under the fault condition are as shown in the figure. The winding is protected using a differential current scheme with current transformers of ratio 400/5 A as shown. The current through the operating coil is

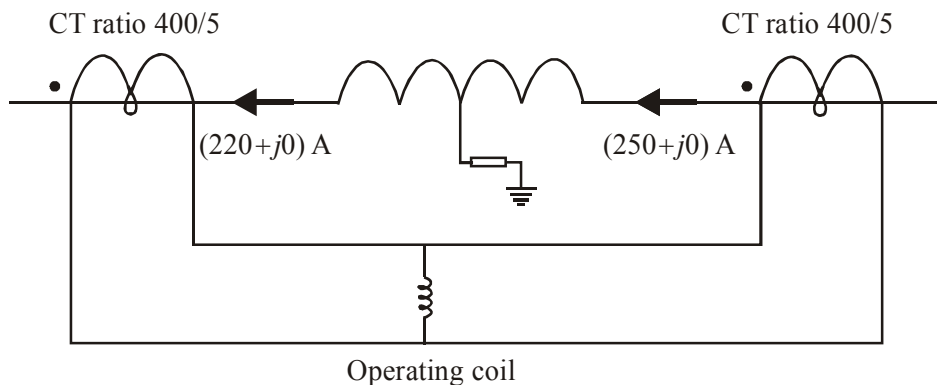

- (A) 0.1875 A                      (B) 0.2 A                      (C) 0.375 A                      (D) 60 kA

Q.20 The zero-sequence circuit of the three phase transformer shown in the figure is

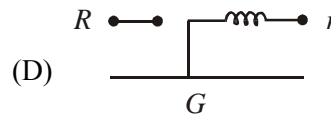
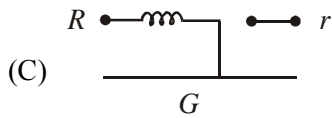
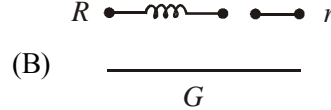
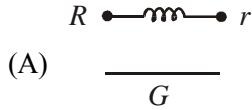
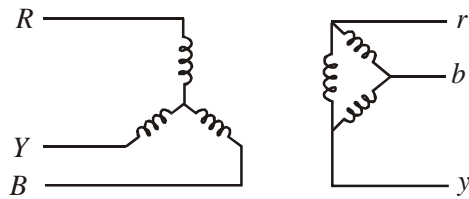

Q.21 Given that the op-amp is ideal, the output voltage  $V_0$  is

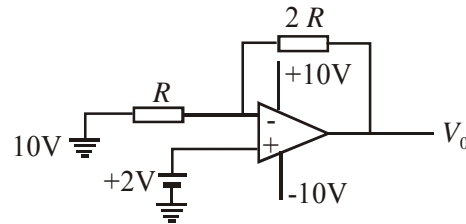

- (A) 4 V                      (B) 6 V                      (C) 7.5 V                      (D) 12.12 V

Q.22 Assuming that the diodes in the given circuit are ideal, the voltage  $V_0$  is

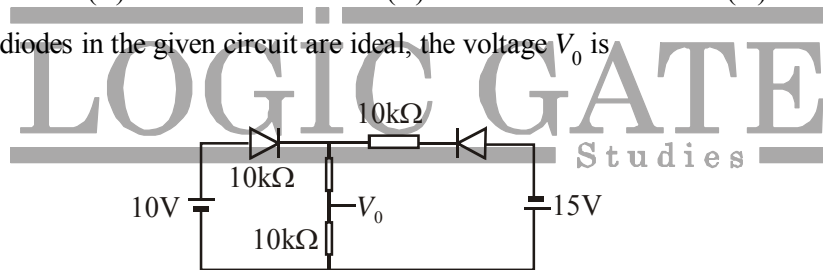

- (A) 4 V                      (B) 5 V                      (C) 7.5 V                      (D) 12.12 V

Q.23 The power electronic converter shown in figure has a single-pole double-throw switch. The pole P of the switch is connected alternately to throws A and B. The converter shown is a

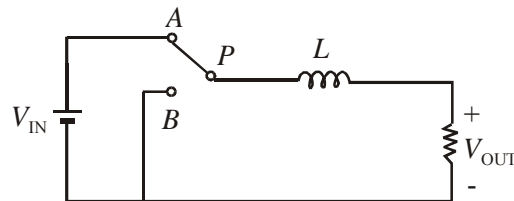

- (A) Step-down chopper (buck converter)                      (B) Half-wave rectifier  
 (C) Step-up chopper (boost converter)                      (D) Full-wave rectifier

- Q.24 Figure shows a composite switch consisting of a power transistor (BJT) in series with a diode. Assuming that the transistor switch and the diode are ideal, the I-V characteristic of the composite switch is

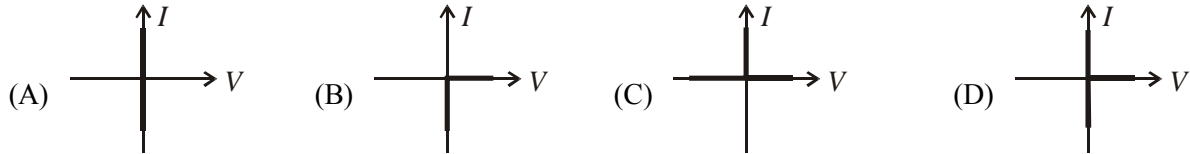
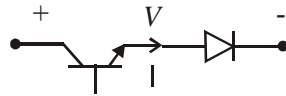

- Q.25 The fully controlled thyristor converter in the figure is fed from a single-phase source. When the firing angle is  $0^\circ$ , the dc output voltage of the converter is 300 V. What will be the output voltage for a firing angle of  $60^\circ$ , assuming continuous conduction?

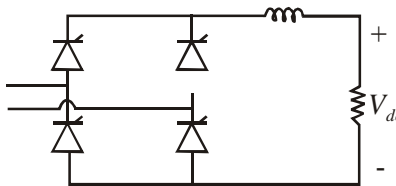

- (A) 150 V (B) 210 V (C) 300 V (D)  $100\pi$  V

Q.26-Q.55 carry two marks each

- Q.26 At  $t = 0$ , the function  $f(t) = \frac{\sin t}{t}$  has  
 (A) A minimum (B) A discontinuity (C) A point of inflection (D) A maximum
- Q.27 A box contains 4 white balls and 3 red balls. In succession, two ball is white, the probability that the second removed ball is red is  
 (A)  $1/3$  (B)  $3/7$  (C)  $1/2$  (D)  $4/7$

- Q.28 An eigenvector of  $P = \begin{pmatrix} 1 & 1 & 0 \\ 0 & 2 & 2 \\ 0 & 0 & 3 \end{pmatrix}$  is  
 (A)  $[-1 \ 1 \ 1]^T$  (B)  $[1 \ 2 \ 1]^T$  (C)  $[1 \ -1 \ 2]^T$  (D)  $[2 \ 1 \ -1]^T$

- Q.29 For the differential equation  $\frac{d^2x}{dt^2} + 6\frac{dx}{dt} + 8x = 0$  with initial conditions  $x(0) = 1$  and  $\left. \frac{dx}{dt} \right|_{t=0} = 0$ , the solution is  
 (A)  $x(t) = 2e^{-6t} - e^{-2t}$  (B)  $x(t) = 2e^{-2t} - e^{-4t}$  (C)  $x(t) = -e^{-6t} + 2e^{-4t}$  (D)  $x(t) = e^{-2t} + 2e^{-4t}$

Q.30 For the set of equations

$$x_1 + 2x_2 + x_3 + 4x_4 = 2$$

$$3x_1 + 6x_2 + 3x_3 + 12x_4 = 6$$

the following statement is true :

- (A) Only the trivial solution  $x_1 = x_2 = x_3 = x_4 = 0$  exists
- (B) There are no solutions
- (C) A unique non-trivial solutions exists
- (D) Multiple non-trivial solutions exist

Q.31  $x(t)$  is a positive rectangular pulse from  $t = -1$  to  $t = +1$  with unit height as shown in the figure. The value of

$$\int_{-\infty}^{\infty} |X(\omega)|^2 d\omega \{ \text{where } X(\omega) \text{ is the Fourier transform of } x(t) \}$$
 is

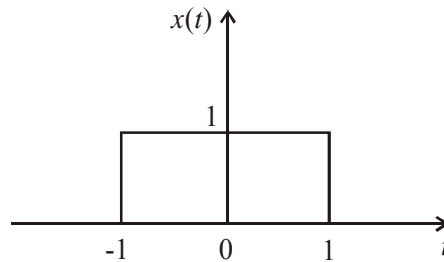

- (A) 2
- (B)  $2\pi$
- (C) 4
- (D)  $4\pi$

Q.32 Given the finite length input  $x[n]$  and the corresponding finite length output  $y[n]$  of an LTI system as shown below, the impulse response  $h[n]$  of the system is

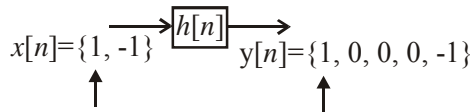

- (A)  $h[n] = \{1, 0, 0, 1\}$
- (B)  $h[n] = \{1, 0, 1\}$
- (C)  $h[n] = \{1, 1, 1, 1\}$
- (D)  $h[n] = \{1, 1, 1\}$

Q.33 If the  $12\Omega$  resistor draws a current of 1 A as shown in figure, the value of resistance  $R$  is

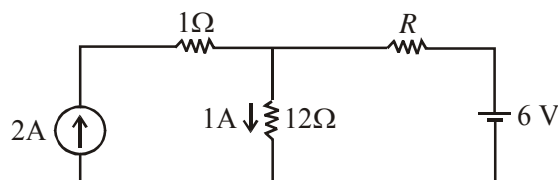

- (A)  $4\Omega$
- (B)  $6\Omega$
- (C)  $8\Omega$
- (D)  $18\Omega$

Q.34 The two-port network  $P$  shown in the figure has ports 1 and 2, denoted by terminals (a, b) and (c, d), respectively. It has an impedance matrix  $Z$  with parameters denoted by  $Z_{ij}$ . A  $1\Omega$  resistor is connected in series with the network at port 1 as shown in the figure. The impedance matrix of the modified two-port network (shown as a dashed box) is

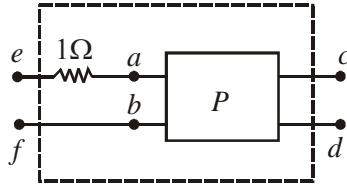

- (A)  $\begin{pmatrix} z_{11} + 1 & z_{12} + 1 \\ z_{21} & z_{22} + 1 \end{pmatrix}$  (B)  $\begin{pmatrix} z_{11} + 1 & z_{12} \\ z_{21} & z_{22} + 1 \end{pmatrix}$  (C)  $\begin{pmatrix} z_{11} + 1 & z_{12} \\ z_{21} & z_{22} \end{pmatrix}$  (D)  $\begin{pmatrix} z_{11} + 1 & z_{12} \\ z_{21} + 1 & z_{22} \end{pmatrix}$

Q.35 The Maxwell's bridge shown in the figure is at balance. The parameters of the inductive coil are

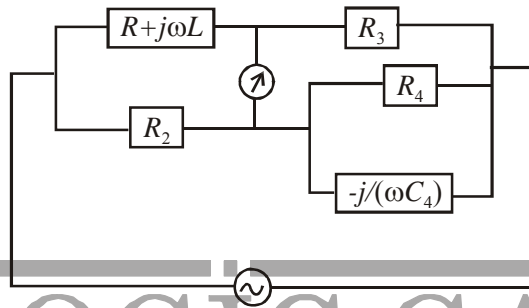

- (A)  $R = R_2 R_3 / R_4, L = C_4 R_2 R_3$  (B)  $L = R_2 R_3 / R_4, R = C_4 R_2 R_3$   
 (C)  $R = R_4 R_2 / R_3, L = 1 / (C_4 R_2 R_3)$  (D)  $L = R_4 / R_2 R_3, R = 1 / (C_4 R_2 R_3)$

Q.36 The frequency response of  $G(s) = 1/[s(s+1)(s+2)]$  plotted in the complex  $G(j\omega)$  plane (for  $0 < \omega < \infty$ ) is

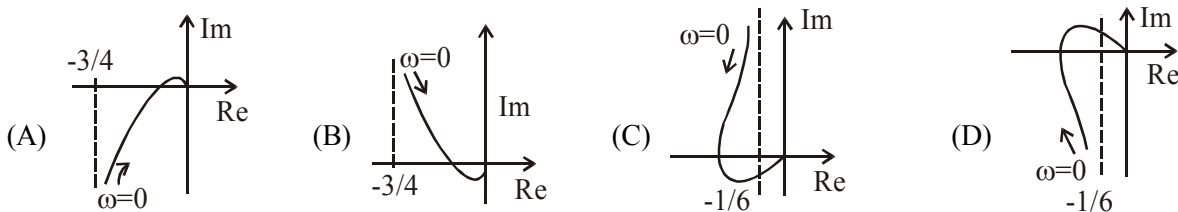

Q.37 The system  $\dot{x} = Ax + Bu$  with  $A = \begin{bmatrix} -1 & 2 \\ 0 & 2 \end{bmatrix}, B = \begin{bmatrix} 0 \\ 1 \end{bmatrix}$  is

- (A) Stable and controllable (B) Stable but uncontrollable  
 (C) Unstable but controllable (D) Unstable and uncontrollable

Q.38 The characteristic equation of a closed-loop system is  $s(s+1)(s+3)+k(s+2)=0, k > 0$ . Which of the following statements is true ?

- (A) Its roots are always real
- (B) It cannot have a breakaway point in the range  $-1 < \text{Re}[s] < 0$
- (C) Two of its roots tend to infinity along the asymptotes  $\text{Re}[s] = -1$
- (D) It may have complex roots in the right half plane

Q.39 A 50 Hz synchronous generator is initially connected to a long lossless transmission line which is open circuited at the receiving end. With the field voltage held constant, the generator is disconnected from the transmission line. Which of the following may be said about the steady state terminal voltage and field current of the generator ?

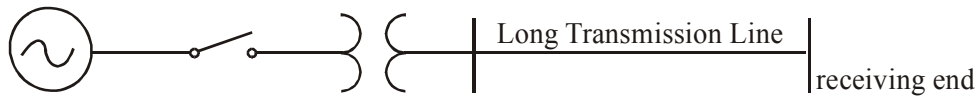

- (A) The magnitude of terminal voltage decreases, and the field current does not change
- (B) The magnitude of terminal voltage increases, and the field current does not change
- (C) The magnitude of terminal voltage increases, and the field current increases
- (D) The magnitude of terminal voltage does not change, and the field current decreases

Q.40 A separately excited dc machine is coupled to a 50 Hz, three-phase, 4-pole induction machine as shown in the figure. The dc machine is energized first and the machines rotate at 1600 rpm. Subsequently the induction machine is also connected to a 50 Hz, three-phase source, the phase sequence being consistent with the direction of rotation. In steady state,

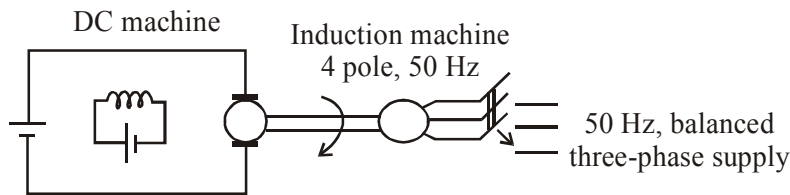

- (A) Both machines act as generators
- (B) The dc machine acts as a generator, and the induction machine acts as a motor
- (C) The dc machine acts as a motor, and the induction machine acts as a generator
- (D) Both machines act as motors

Q.41 A balanced star-connected and purely resistive load is connected at the secondary of a star-delta transformer as shown in the figure. The line-to-line voltage rating of the transformer is 110 V/220 V.

Neglecting the non-idealities of the transformer, the impedance 'Z' of the equivalent star-connected load, referred to the primary side of the transformer, is:

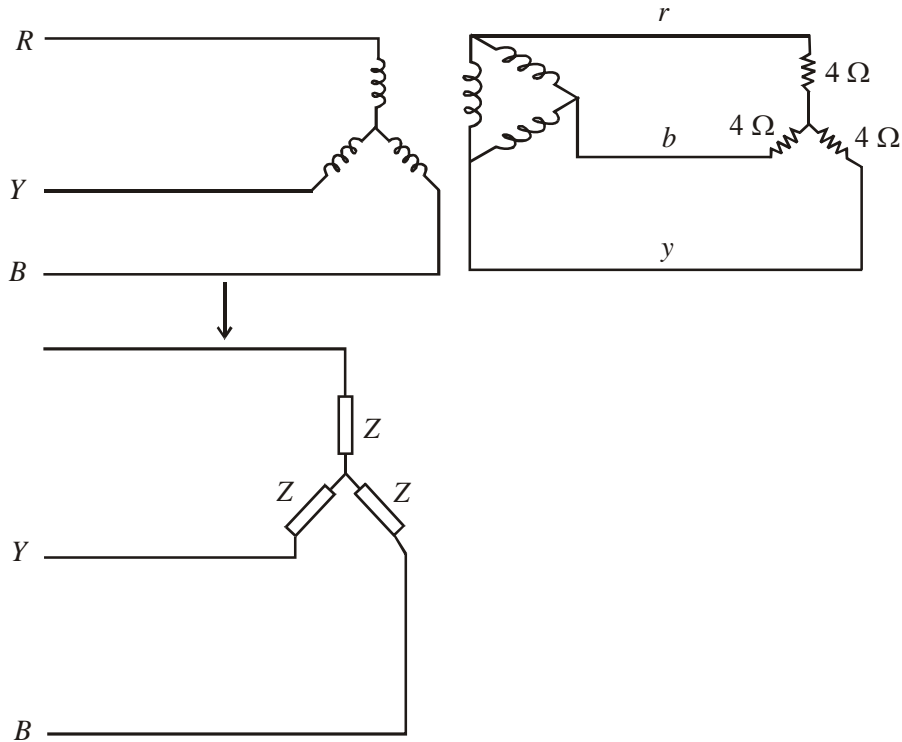

- (A)  $(3 + j0)\Omega$       (B)  $(0.866 - j0.5)\Omega$       (C)  $(0.866 + j0.5)\Omega$       (D)  $(1 + j0)\Omega$

Q.42 Consider a three-phase, 50 Hz, 11 kV distribution system. Each of the conductors is suspended by an insulator string having two identical porcelain insulators. The self capacitance of the insulator is 5 times the shunt capacitance between the link and the ground, as shown in the figure. The voltage across the two insulators are

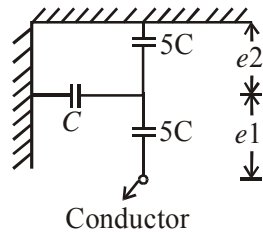

- (A)  $e_1 = 3.74 \text{ kV}, e_2 = 2.61 \text{ kV}$       (B)  $e_1 = 3.46 \text{ kV}, e_2 = 2.89 \text{ kV}$   
 (C)  $e_1 = 6.0 \text{ kV}, e_2 = 4.23 \text{ kV}$       (D)  $e_1 = 5.5 \text{ kV}, e_2 = 5.5 \text{ kV}$

Q.43 Consider a three-core, three-phase, 50 Hz, 11 kV cable whose conductors are denoted as R, Y and B in the figure. The inter-phase capacitance ( $C_1$ ) between each pair of conductors is  $0.2 \mu\text{F}$  and the capacitance

between each line conductor and the sheath is  $0.4\mu\text{F}$ . The per-phase charging current is

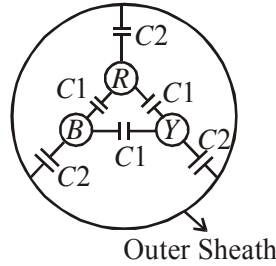

- (A) 2.0 A                      (B) 2.4 A                      (C) 2.7 A                      (D) 3.5 A

Q.44 For the power shown in the figure below, the specifications of the components are the following :

G1 : 25 kV, 100 MVA, X = 9%

G2 : 25 kV, 100 MVA, X = 9%

T1 : 25 kV/220 kV, 90 MVA, X = 12%

T2 : 220 kV/225 kV, 90 MVA, X = 12%

Line 1 : 220 kV, X = 150 ohms

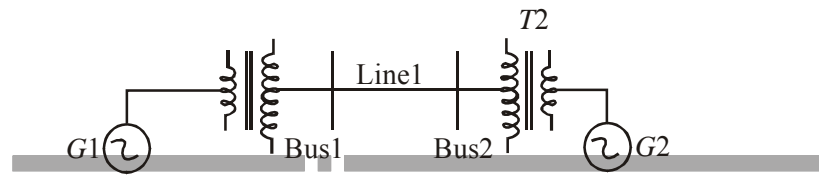

Choose 25 kV as the base voltage at the generator G1, and 200 MVA as the MVA as the MVA base. The impedance diagram is

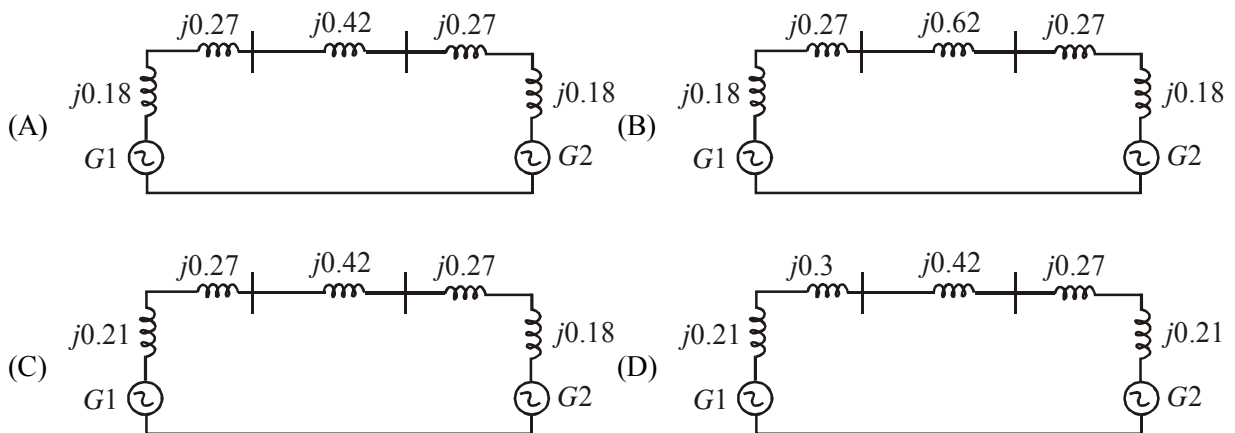

- Q.45 The transistor circuit shown uses a silicon transistor with  $V_{BE} = 0.7\text{V}$ ,  $I_C \approx I_E$  and a dc current gain of 100. The value of  $V_0$  is

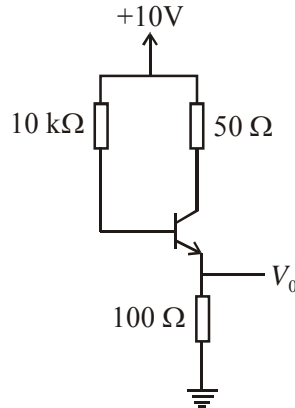

- (A) 4.65 V                      (B) 5 V                      (C) 6.3 V                      (D) 7.23 V
- Q.46 The TTL circuit shown in the figure is fed with the waveform X (also shown). All gates have equal propagation delay of 10 ns. The output Y of the circuit is

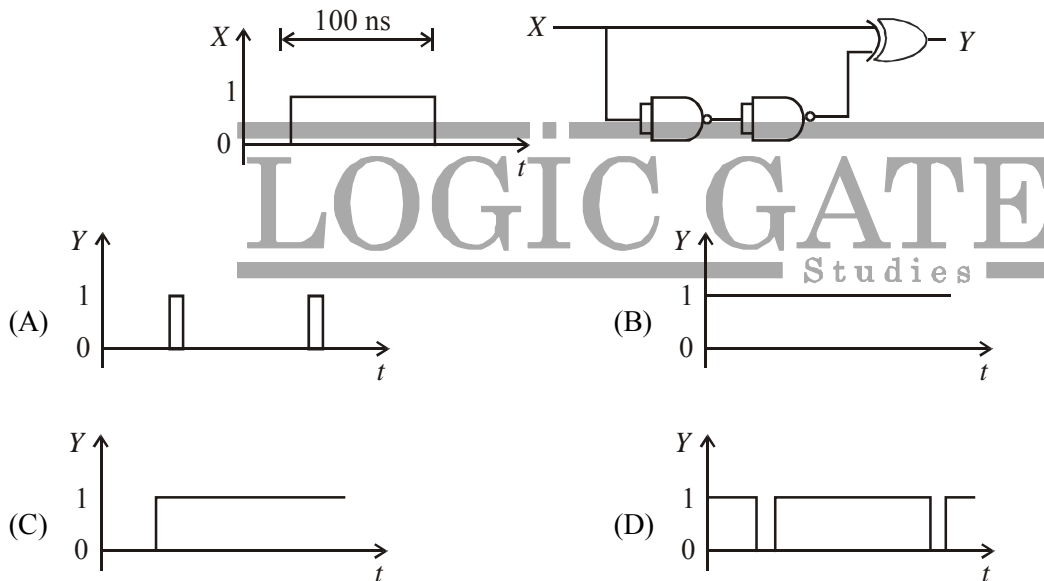

- Q.47 When a “CALL Addr” instruction is executed, the CPU carries out the following sequential operations internally :
- (R) Means content of register R
  - ((R)) Means content of memory location pointed to by R
  - PC Means Program Counter
  - SP Means Stack Pointer

- |  |  |
|--|--|
| (A) (SP) incremented<br>(PC) ← Addr<br>((SP)) ← (PC) | (B) (PC) ← Addr<br>((SP)) ← (PC)<br>(SP) incremented |
| (C) (PC) ← Addr<br>(SP) incremented<br>((SP)) ← (PC) | (D) ((SP)) ← (PC)<br>(SP) incremented<br>(PC) ← Addr |

**Common Data Questions**

**Common Data for Questions 48 and 49 :**

A separately excited DC motor runs at 1500 rpm under no-load with 200 V applied to the armature. The field voltage is maintained at its rated value. The speed of the motor, when it delivers a torque of 5 Nm, is 1400 rpm as shown in the figure. The rotational losses and armature reaction are neglected.

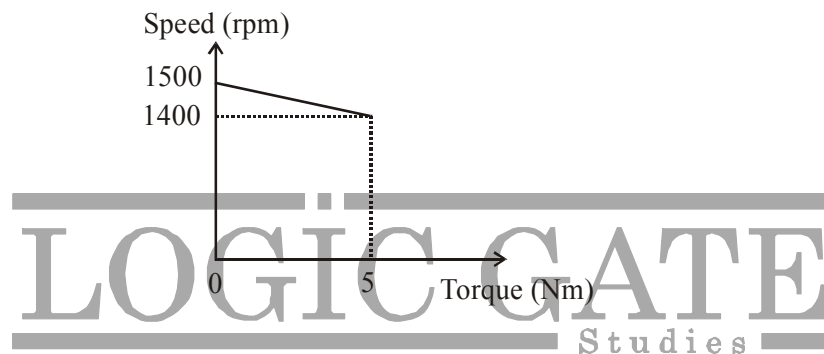

- Q.48 The armature resistance of the motor is  
 (A)  $2\Omega$                       (B)  $3.4\Omega$                       (C)  $4.4\Omega$                       (D)  $7.7\Omega$
- Q.49 For the motor to deliver a torque of 2.5 Nm at 1400 rpm, the armature voltage to be applied is  
 (A) 125.5 V                      (B) 193.3 V                      (C) 200 V                      (D) 241.7 V

**Common Data for Questions 50 and 51**

Given  $f(t)$  as shown below :

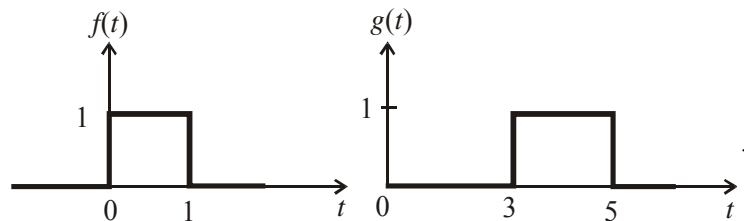

Q.50  $g(t)$  can be expressed as

- (A)  $g(t) = f(2t - 3)$  (B)  $g(t) = f\left(\frac{t}{2} - 3\right)$  (C)  $g(t) = f\left(2t - \frac{3}{2}\right)$  (D)  $g(t) = f\left(\frac{t}{2} - \frac{3}{2}\right)$

Q.51 The Laplace transform of  $g(t)$  is

- (A)  $\frac{1}{s}(e^{3s} - e^{5s})$  (B)  $\frac{1}{s}(e^{-5s} - e^{-3s})$  (C)  $\frac{e^{-3s}}{s}(1 - e^{-2s})$  (D)  $\frac{1}{s}(e^{-5s} - e^{3s})$

**Linked Answer Questions**

**Statement for Linked Answer Questions 52 and 53 :**

The following Karnaugh map represents a function  $F$ .

		YZ			
		00	01	11	10
X	0	1	1	1	0
	1	0	0	1	0

Q.52 A minimized form of the function  $F$  is

- (A)  $F = \overline{X}Y + YZ$  (B)  $F = \overline{X}\overline{Y} + YZ$  (C)  $F = \overline{X}\overline{Y} + Y\overline{Z}$  (D)  $F = \overline{X}\overline{Y} + \overline{Y}Z$

Q.53 Which of the following circuits is a realization of the above function  $F$ ?

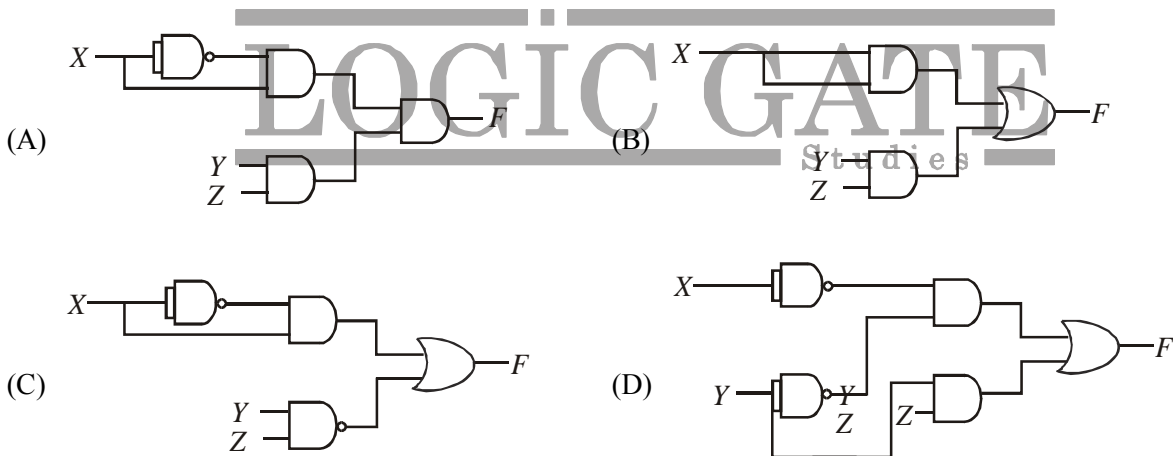

**Statement for Linked Answer Questions 54 and 55**

The L-C circuit shown in the figure has an inductance  $L = 1 \text{ mH}$  and a capacitance  $C = 10\mu\text{F}$

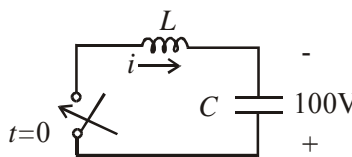

Q.54 The initial current through the inductor is zero, while the initial capacitor voltage is 100 V. The switch is closed at  $t = 0$ . The current  $i$  through the circuit is :

- (A)  $5 \cos(5 \times 10^3 t)$  A                      (B)  $5 \sin(10^4 t)$  A  
 (C)  $10 \cos(5 \times 10^3 t)$  A                      (D)  $10 \sin(10^4 t)$  A

Q.55 The L-C circuit of Q.54 is used to commutate a thyristor, which is initially carrying a current of 5 A as shown in the figure below. The values and initial conditions of  $L$  and  $C$  are the same as in Q.54. The switch is closed at  $t = 0$ . If the forward drop is negligible, the time taken for the device to turn off is

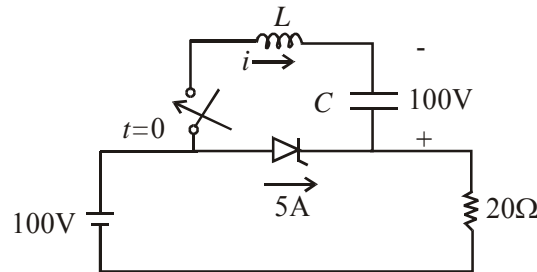

- (A)  $52 \mu\text{s}$                       (B)  $156 \mu\text{s}$                       (C)  $312 \mu\text{s}$                       (D)  $26 \mu\text{s}$

**General Aptitude (GA) Questions**

**Q.56 - Q.60 carry one mark each.**

Q.56 25 persons are in a room. 15 of them play hockey, 17 of them play football and 10 of them play both hockey and football. Then the number of persons playing neither hockey nor football is :  
 (A) 2                      (B) 17                      (C) 13                      (D) 3

Q.57 Choose the most appropriate word from the options given below to complete the following sentence :  
**If we mangle to \_\_\_\_\_ our natural resources, we would leave a better planet for our children.**  
 (A) Uphold                      (B) Restrain                      (C) Cherish                      (D) Conserve

Q.58 The question below consists of a pair of related words followed by four pairs of words. Select the pair that best expresses the relation in the original pair.

**Unemployed : Worker**

- (A) Fallow : land                      (B) Unaware : sleeper                      (C) Wit : jester                      (D) Renovated : house

Q.59 Which of the following options is the closest in meaning to the word below :

**Circuitous**

- (A) Cyclic                      (B) Indirect                      (C) Confusing                      (D) Crooked

Q.60 Choose the most appropriate word from the options given below to complete the following sentence :  
**His rather casual remarks on politics \_\_\_\_\_ His lack of seriousness about the subject.**

- (A) Masked                      (B) Belied                      (C) Betrayed                      (D) Suppressed

**Q.61 - Q.65 carry to marks each.**

Q.61 Hari (H), Gita (G), Irfan (I) and Saira (S) are siblings (i.e. brothers and sisters). All were born on 1<sup>st</sup> January. The age difference between any two successive siblings (that is born one after another) is less than 3 years. Given the following facts :

- i. Hari's age + Gita's age > Irfan's age + Saira's age.
- ii. The age difference between Gita and Saira is 1 year. However, Gita is not the oldest and Saira is not the youngest.
- iii. There are no twins.

In what order were they born (oldest first) ?

- (A) HSI G                      (B) SGHI                      (C) IGSH                      (D) IHSG

Q.62 5 skilled workers can build a wall in 20 days; 8 semi-skilled workers can build a wall in 25 days; 10 unskilled workers can build a wall in 30 days. If a team has 2 skilled, 6 semi-skilled and 5 unskilled workers, how long will it take to build the wall ?

- (A) 20 days                      (B) 18 days                      (C) 16 days                      (D) 15 days

Q.63 **Modern warfare has changed from large scale clashes of armies to suppression of civilian populations. Chemical agents that do their work silently appear to be suited to such warfare; and regrettably, there exist people in military establishments who think that chemical agents are useful tools for their cause.**

*Which of the following statements best sums up the meaning of the above passage :*

- (A) Modern warfare has resulted in civil strife  
 (B) Chemical agents are useful in modern warfare  
 (C) Use of chemical agents in warfare would be undesirable  
 (D) People in military establishments like to use chemical agents in war

Q.64 Given digits 2, 2, 3, 3, 3, 4, 4, 4, 4 how many distinct 4 digit numbers greater than 3000 can be formed ?

- (A) 50                      (B) 51                      (C) 52                      (D) 54

Q.65 If  $137 + 276 = 435$  how much is  $731 + 672$  ?

- (A) 534                      (B) 1403                      (C) 1603                      (D) 1513

***End of the Question Paper***